

OVAL GEAR FLOWMETER MECHANICAL MODEL 050 (2")

INSTRUCTION MANUAL



To the Owner

**PLEASE READ THIS SAFETY INFORMATION
CAREFULLY BEFORE USE.**

Read and retain this instruction manual to assist you in the operation and maintenance of this product.

If you have any problems with the meter, refer to the maintenance and trouble shooting sections of this manual.

This manual contains connection and operating instructions for meters with Mechanical Displays

If you need further assistance, contact your local representative or distributor for advice.

This Flow Meter has incorporated the oval rotor principal into its design. This has proven to be a reliable and highly accurate method of measuring flow.

Exceptional repeatability and high accuracy over a wide range of fluid viscosities and flow rates are features of the oval rotor design. With a low pressure drop and high pressure rating oval rotor flow meters are suitable for both gravity and pump (in line) applications.

Important Information



WARNING

Before use, confirm the fluid to be used is compatible with the meter. Refer to Industry fluid compatibility charts or consult your local representative for advice.

To prevent damage from dirt or foreign matter it is recommended that a Y or Basket type 60 mesh strainer be installed as close as possible to the inlet side of the meter. Contact your local representative for advice.



CAUTION

When a strainer is installed it should be regularly inspected and cleaned. Failure to keep the strainer clean will dramatically effect flow meter performance.



CAUTION

To prevent damage caused by air purge slowly fill the meter with fluid. To reduce pressure build up turn off the pump at the end of each day.

Maintenance can be carried out to the liquid crystal displays and pulse units without removing or isolating the meter from the line. When maintenance to any other part of the meter is required, the meter must be isolated and the line pressure reduced.

The reed switch pulse unit can cause inaccurate rate counts when used with high speed counters. It is advised that a debounce circuit be used. Contact your meter distributor for further information.

Operating Principle

When fluid passes through the meter the rotors turn, as shown below. The magnets which are located in the rotors will pass across the pulser circuit board (containing either Reed switches or Hall Effect sensors). A signal is generated which is then sent by the Pulse Circuit Board (PCB) to the relevant LC display or receiving instrument..

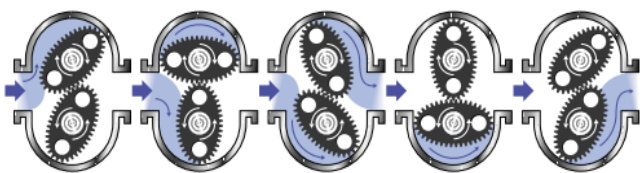

Installation Procedure

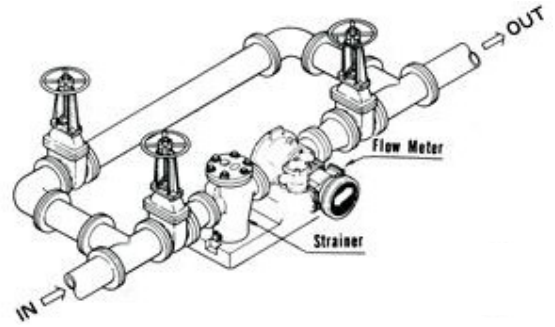

- 1) It is recommended that when setting up pipe work for meter installations a bypass line be included in the design. This provides the facility for a meter to be removed for maintenance without interrupting production. (see figure above)
- 2) Use thread sealant on all pipe threads.
- 3) For pump applications ensure pipe work has the appropriate working pressure rating to match the pressure output of the pump. See Meter Specifications section for further details.
- 4) Install a wire mesh strainer, Y or basket type 60 mesh (250 micron), as close as possible to the inlet side of the meter.
- 5) Ensure that the meter is installed so that the flow of the liquid is in the direction of the arrows embossed on the meter body.
- 6) The meter can be installed in any orientation as long as the meter shafts are in a horizontal plane. (Refer to figures to the right for correct installation) The register assembly may be orientated to suit the individual.
Note: Incorrect installation can cause premature wear of meter components.



- 7) Do not over tighten meter connections. Note: Incorrect installation can cause premature wear of meter components.
- 8) It is important that after initial installation you fill the line slowly, high speed air purge could cause damage to the rotors.
- 9) Test the system for leaks.
- 10) Check the strainer for swarf or foreign material, after the first 200 litres check periodically, particularly if the flow rate decreases.

Maintenance Procedures

Disassembly - Flow Meter

Ensure that the fluid supply to the meter is disconnected, and the line pressure is released before disassembly.

Refer to the exploded parts diagram and parts list, for item numbers.

- 1) Remove the four screws located on the face of the register. Then remove the face plate cover including register assembly.
- 2) Remove the four register mounting screws and remove the lower half of the register housing.
- 3) Remove the six cover plate screws (Item 12) and remove the cover plate (Item 11).
- 4) Remove the six meter cap screws (Item 5) and remove the meter cap (Item 4).
- 5) Remove rotors (Item 3).

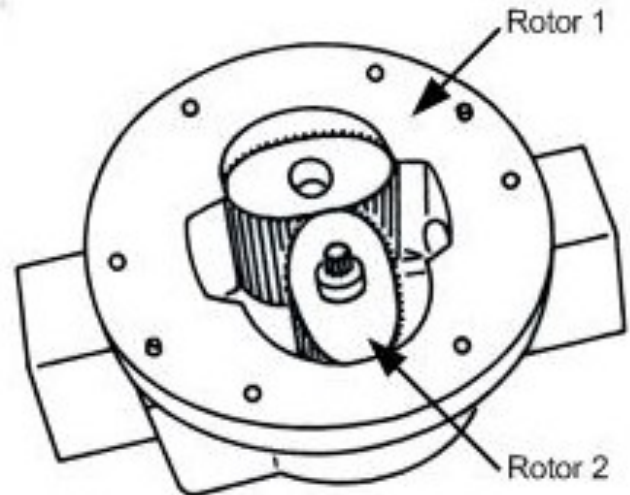

Rotors Must be 90° to each other

Reassembly - Flow Meter

- 1) Before reassembling check the condition of the rotors (replace if necessary).
- 2) Check that the smooth side of the rotors (not the plug side) is facing you when inserting the rotors, the smooth side of the rotor is the magnet side. There is no difference between rotor one or rotor two.
- 3) Replace the rotors (Item 3) onto the shafts at 90 degrees to each other (refer Fig) and check their operation by turning either of the rotors. If the rotors are not in mesh correctly or do not move freely, remove one of the rotors and replace correctly at 90 degrees to the other rotor.
- 4) Re-check the operation of the rotors
- 5) Inspect the gears (Item 6) in the meter cap (Item 4) for wear. (Replace if required, refer to parts on page 4)
- 6) Replace the o-ring (Item 2) into groove in the meter cap, if the o-ring has grown or is damaged in any way replace it with a new part.
- 7) Replace the meter cap making sure that the gear on the rotor is meshing correctly with the gear in the meter cap (Item 4). Insert the cap head screws (Item 5) and tighten in a diagonal sequence 1, 4, 2, 5, 3, 6.
- 8) Replace the cover plate inspect the o-ring (item 10), bevel gear (Item 7), for wear or damage. (Replace if necessary).

Product Specifications

Flowmeter Mech

			Metric	US
'F' and 'M' Meters	Flow Range	Below 5 cP	15 to 500 L/min	4 to 130 G/min
		5 to 1000 cP	15 to 500 L/min	4 to 130 G/min
'S' Meters	Flow Range	Below 5 cP	15 to 500 L/min	4 to 130 G/min
		5 to 1000 cP	15 to 500 L/min	4 to 130 G/min
Maximum Operating Temperature (Standard / High Temperature)			80°C / 120°C	176°F / 248°F
Maximum Operating Pressure'			3400 kPa	500 psi
Accuracy of Reading			±0.5%	

1. Conforms to Directive 97/23/EC—Cat 1

Troubleshooting Guide

Problem	Cause	Remedy
Fluid will not flow through meter	<ul style="list-style-type: none"> a) Foreign matter blocking rotors b) Line strainer blocked c) Damaged rotors d) Meter connections over tightened e) Fluid is too viscous 	<ul style="list-style-type: none"> a) Dismantle meter, clean rotors (strainer must be fitted in line) b) Clean strainer c) Replace rotors (Strainer must be fitted in line) d) Re-adjust connections e) See specifications for maximum viscosity
Reduced flow through meter	<ul style="list-style-type: none"> a) Strainer is partially blocked b) Fluid is too viscous 	<ul style="list-style-type: none"> a) Clean strainer b) See specifications for maximum viscosity
Meter reading inaccurate	<ul style="list-style-type: none"> a) Fluid flow rate is too high or too low b) Air in fluid c) Excess wear caused by incorrect installation 	<ul style="list-style-type: none"> a) See specifications for minimum and maximum flow rates b) Bleed air from system c) Check meter body and rotors. Replace as required. Refer to installation instructions
Fluid flows but no reading on meter	<ul style="list-style-type: none"> a) Bevel gear is loose on shaft b) Rotor drive gear is damaged c) Transmission gears damaged d) Register gears damaged 	<ul style="list-style-type: none"> a) Tighten grub screws b) Replace rotor c) Replace gears d) Replace register assembly
Fluid leaks into register	<ul style="list-style-type: none"> a) Seal worn or damaged on the cover plate 	<ul style="list-style-type: none"> a) Replace seal (Check seal compatibility with fluid)

Exploded Diagram

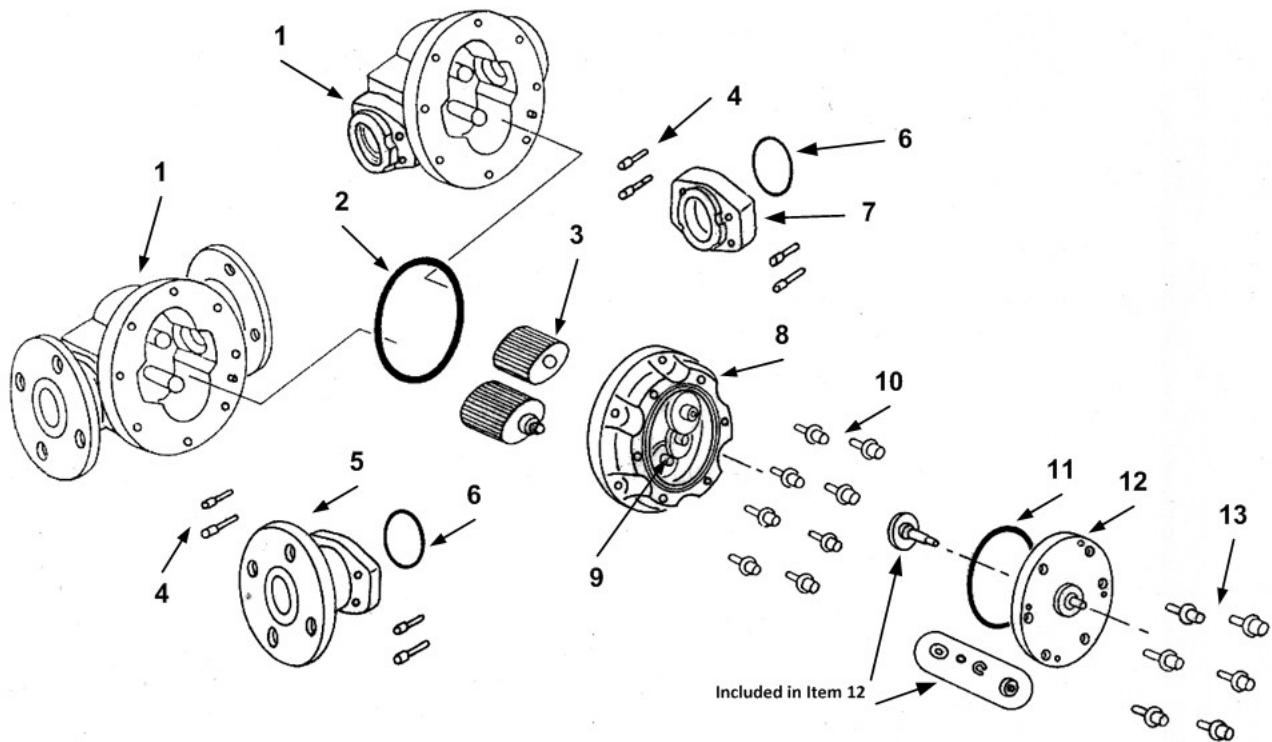

Parts Identification

Item No.	Part Description
1	Meter Body
2	Meter Cap O-Ring
3	Rotor Set
4	Adaptor Bolts
5	Flanged Process Connection
6	Adaptor O-Rings
7	Threaded Process Connection
8	Meter Cap
9	Gear Set
10	Meter Cap Screws
11	Cover Plate O-Ring
12	Cover Plate and Gear Set
13	Cover Plate Screws

Spare Parts Kits

There are 4 **Spare Kit** options available for the purchase of replacement components:

- Output Gear Kit (GKit) - Replacement Drive Gear Set to Mechanical Register.
- Flange Kit (FSKit) - O-Ring set for Flanges
- Rotor Kit (RKit) - Complete Rotor assembly
- Seal Kit (SKit) - Complete set of O-Rings/Gaskets

Spare Kit Coding Procedure.

1. Determine what type of Spare Parts Kit is required (e.g. Rotor Kit)
2. Use the 'Coding Sequence' to construct a part number according to the meter type.

Output Gear - (GKit)

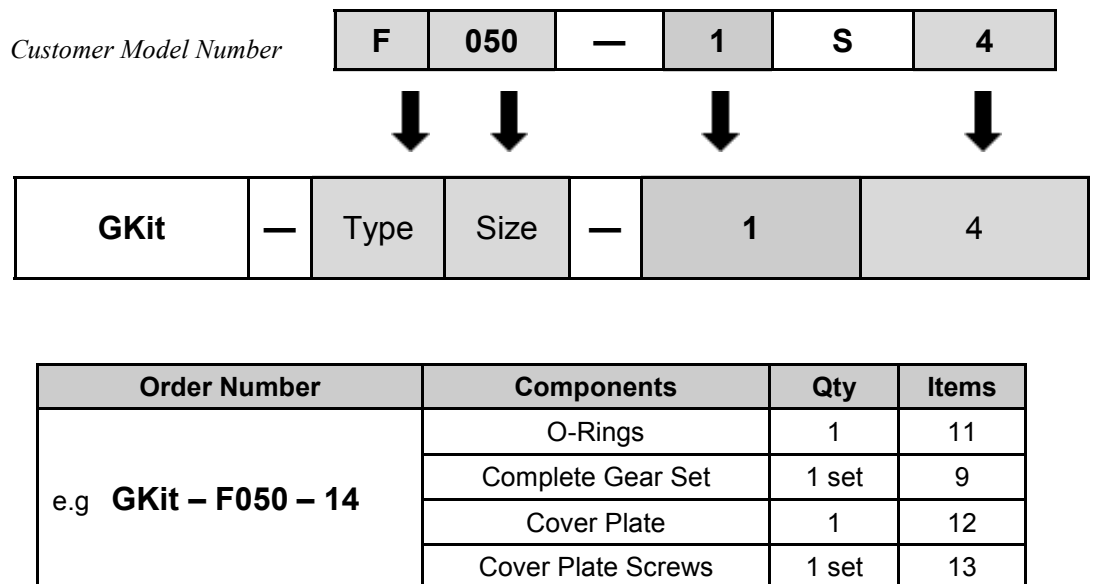

Flange Seal Kit - (FSKit)

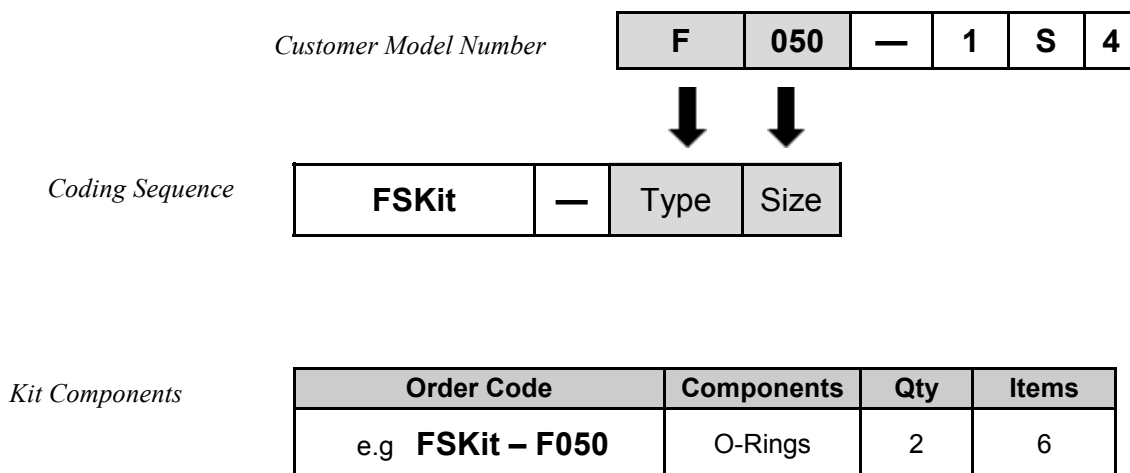

Seal Kit - (SKit)

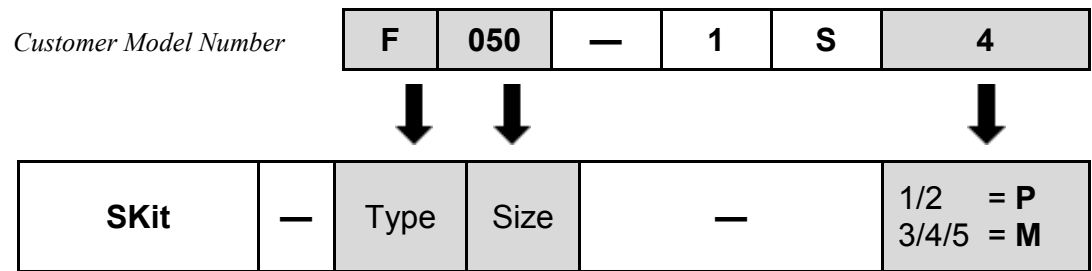

Kit Components

Order Number	Components	Qty	Items
e.g SKit – F050 – M	Cover Plate O-Ring	1	11
	Meter Body O-Ring	1	2

Rotor Kit - (RKit)

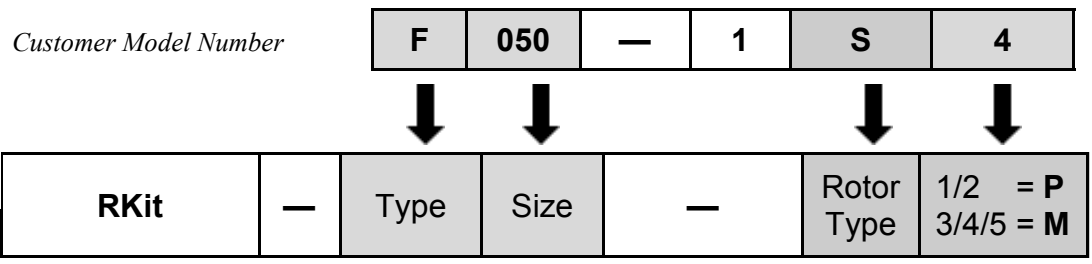

Kit Components

Order Number	Components	Qty	Items
e.g RKit – F050 – SM	Complete Rotor Assembly	1 set	3
	Meter Body O-Rings	1	2
	Meter Cap Screws	8	10

Wetted Parts

Component	Type 'F'	Type 'S'	Type 'M'
Meter Body	Al	Al	SS
Rotor Shaft	SS	SS	SS
Rotors - Standard	PPS	Al	PPS
- High Temp.	-	-	SS
- High Viscosity.	PPS	SS	SS
Rotor Bushes	-	CA	CA
Meter Cap	Al	Al	SS
Gear Assembly	SS/POM	SS/POM	SS/POM
Cover Plate	SS	SS	SS
Output Gear and Shaft assy.	SS/FFKM/POM	SS/FFKM/POM	SS/FFKM/POM
O Rings	FKM	K	K

K - FEP/PTFE Encapsulated

Br - Brass

SS - Stainless Steel 316 /304

Al - Aluminium AA610

CA - Carbon

FKM - Viton[®]

PPS - Polyphenylene Sulphide

PVDF - Polyvinylidene Flouride

POM - Acetal

PTFE - Polytetrafluoroethylene

FFKM - Perfluoro Elastomer

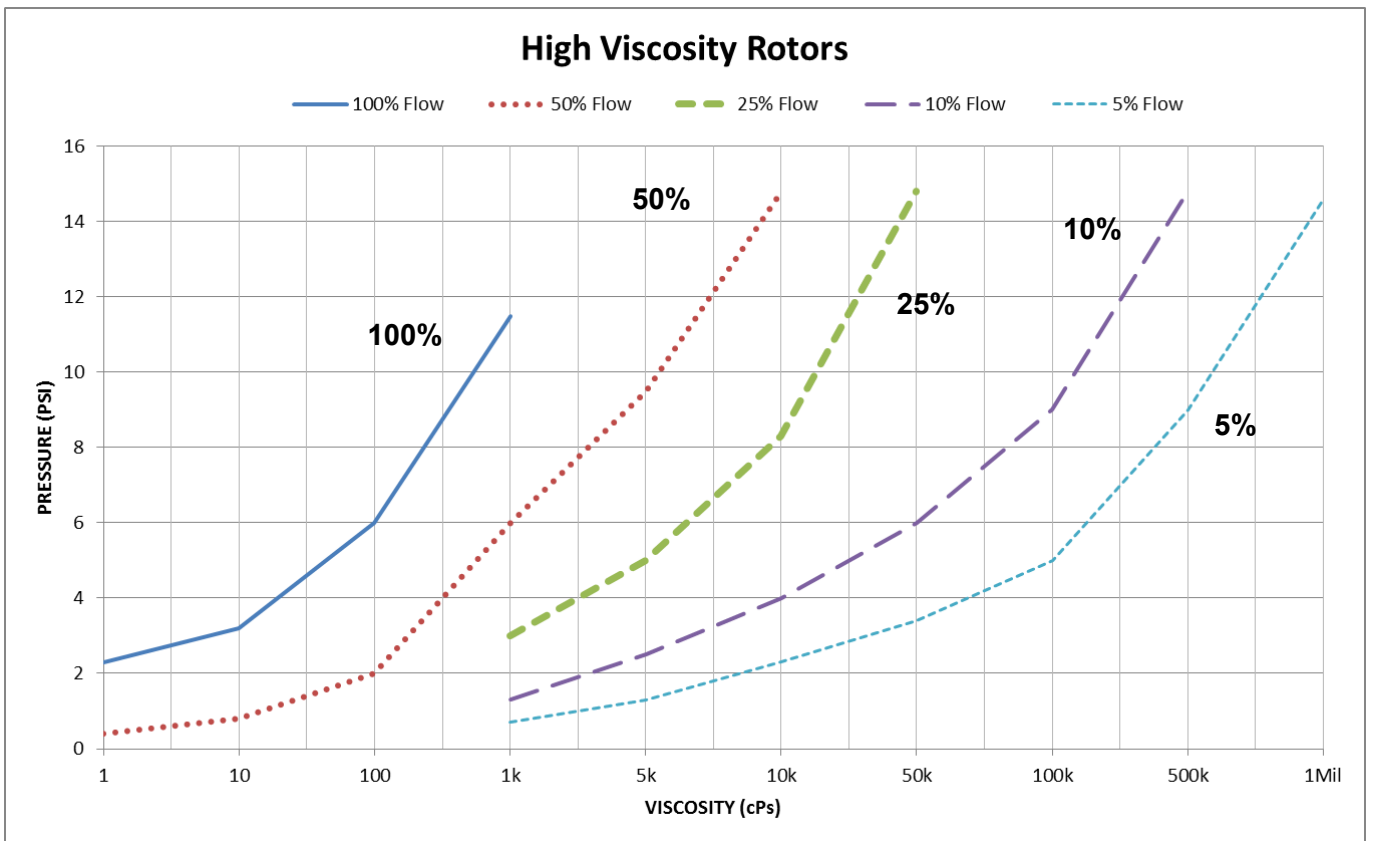
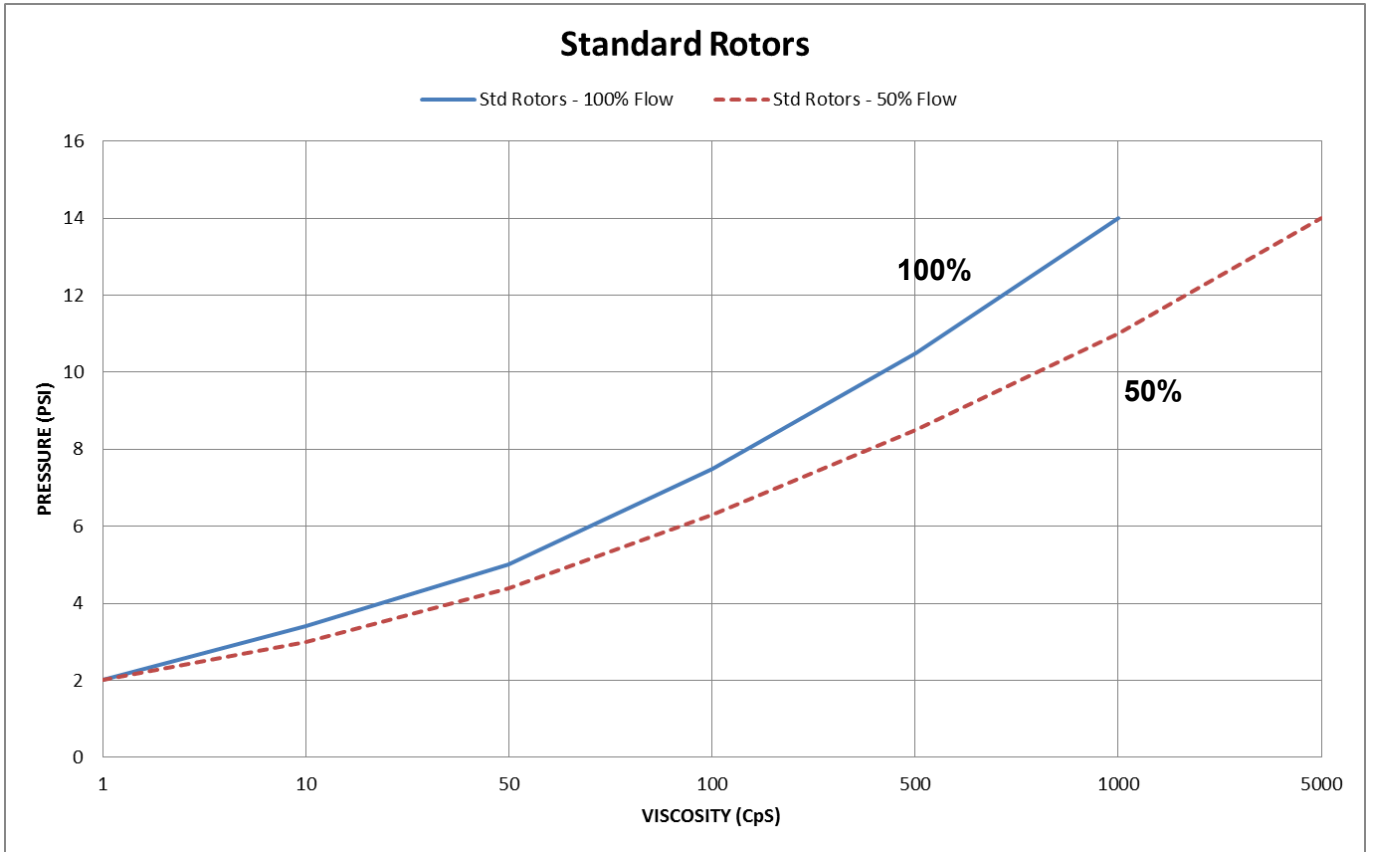

	A - Face to Face Length		C - Flange Diameter	
	F and S Series' (Al)	M Series (SS)	F and S Series' (Al)	M Series (SS)
ANSI	264	264	152	152
DIN	264	264	165	165
JIS	264	264	155	155
RP/NPT	210	210		

	B - Register Height	
	F and S Series' (Al)	M Series (SS)
M	210	210
MK	237	237
MA	248	248

M Register

MK Register

MA Register

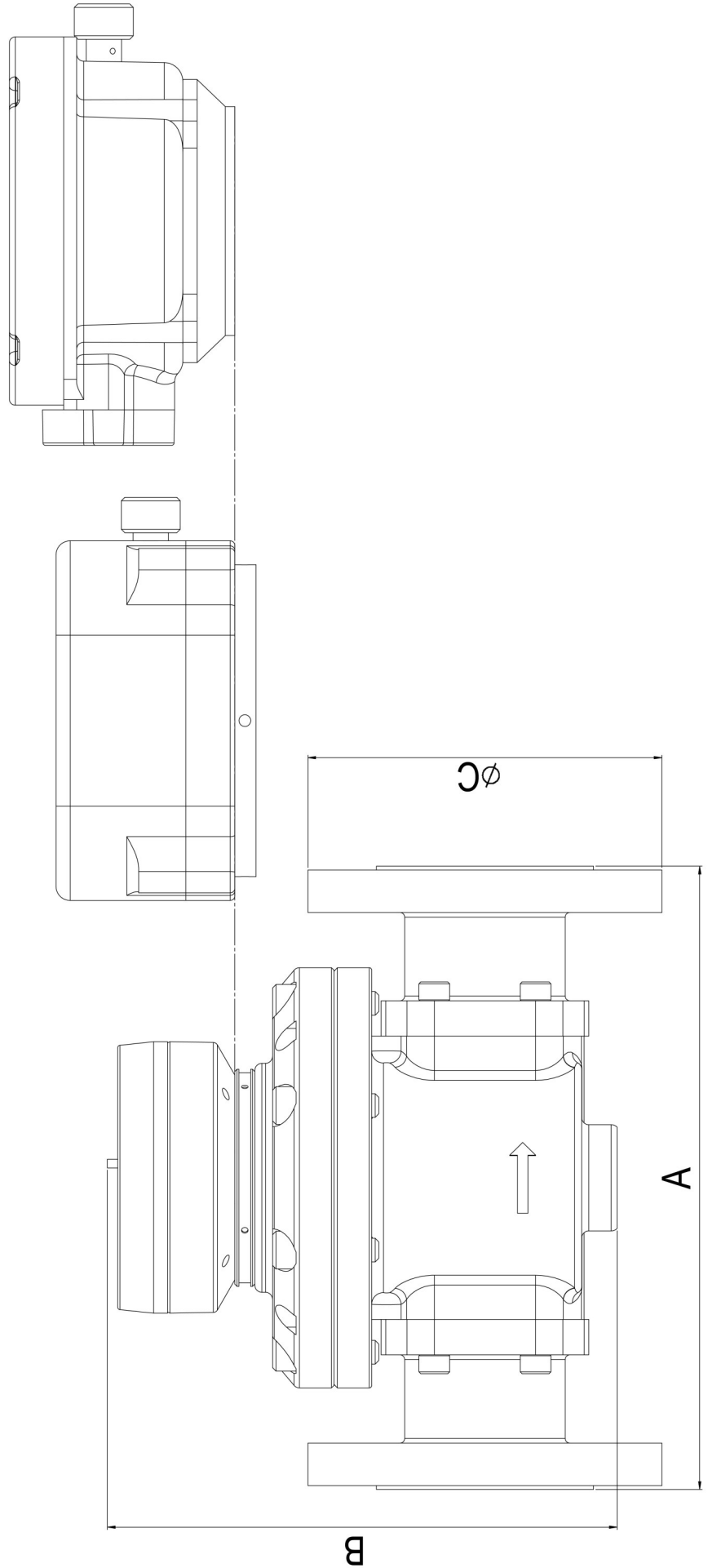

2" Flange

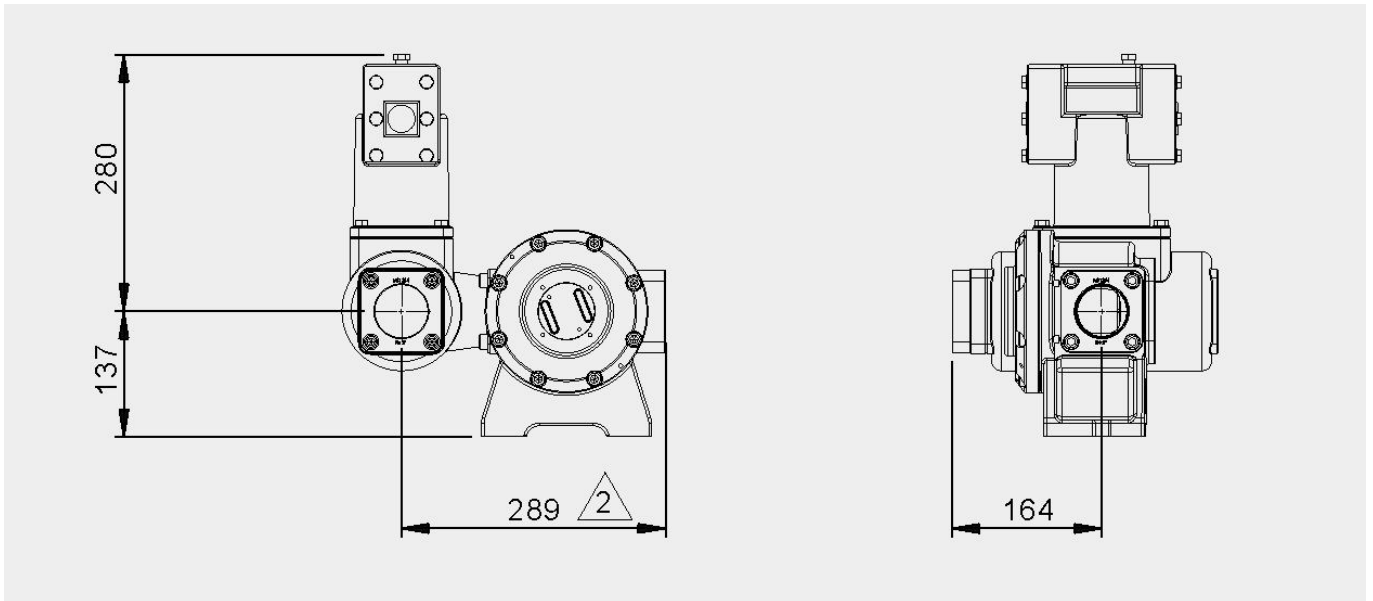

2" Threaded Connection

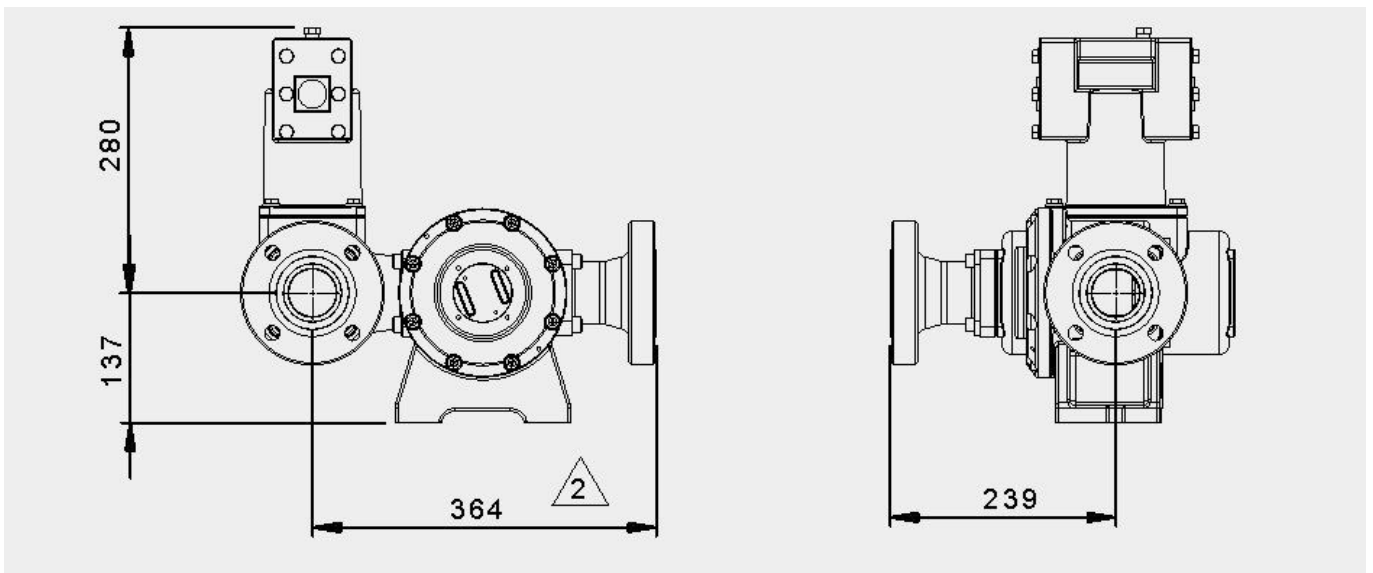

WEEE Directive - Waste Electrical and Electronic Equipment



The WEEE Directive requires the recycling of waste electrical and electronic equipment in the European Union.

Whilst the WEEE Directive does not apply to some of Macnaught's products, we support its policy and ask you to be aware of how to dispose of this product.

The crossed out wheeled bin symbol illustrated and found on our products signifies that this product should not be disposed of in general waste or landfill.

Please contact your local dealer national distributor or Macnaught Technical Services for information on product disposal.



Macnaught Pty Limited

ABN 66 000 075 785

41-49 Henderson Street
Turrella NSW 2205 Sydney Australia
Postal Address PO Box 90
Amcliffe NSW 2205 Sydney Australia

T: +61 2 9567 0401

F: +61 2 9597 7773

W: www.macnaught.com.au